

**GLOBAL JOURNAL OF ENGINEERING SCIENCE AND RESEARCHES**  
**A SURVEY ON CLUSTERING BASED MOBILITY AWARE ROUTING PROTOCOLS**  
**FOR WSNs**

Swati<sup>\*1</sup> & Er Gagan Dhawan<sup>2</sup>

<sup>\*1</sup>Department of Computer Science Engineering MietMohri, M.Tech Scholar

<sup>2</sup>Department of Computer Science Engineering MietMohri, Assistant Professor

---

**ABSTRACT**

Energy consumption is major constraint in Wireless Sensor Networks(WSNs). Tillnow, numerous routing protocols have been investigated to achieve the energy efficiency. Earlier communication protocols were proposed, which can have large impact on the overall consumption of these networks. These conventional protocols such as direct transmission, minimum-transmission-energy, multi-hop routing, and static clustering may not be suitable for sensor networks. LEACH was proposed to overcome the problems of conventional protocols. In LEACH, cluster heads are randomly rotated in order to divide energy load among all nodes. There are so many protocols which follows the same operation as LEACH. This paper reviews on hierarchical based clustering and evolutionary protocols for heterogeneous WSNs to provide better energy efficiency.

*Keywords: Energy consumption, clustering, heterogeneous wireless sensor networks.*

---

**I. INTRODUCTION**

Wireless sensor networks comprises of low power sensor nodes which have limited wireless communication capabilities and energy resources. WSNs are useful in various applications, such as environmental monitoring, medical care, military applications, etc. The two protocols were proposed for energy analysis in wireless sensor networks such as direct communication and minimum transmission energy (MTE) protocols. By using direct communication protocol, each sensor node directly communicates with the BS, but this requires large transmit power to send the data from each node. If BS is located far from the nodes, direct communication will need large amount of transmit power, where as in MTE, intermediate nodes are used to send data to the BS. These both have limitations such as in direct communication Protocol, only receptions occur at the BS, so either if the BS is close to the nodes, it requires large amount of energy to receive data. Hence, it will quickly drain the energy of nodes. On the other hand, MTE only considers the energy dissipation of the transmitters not of the receivers in order to determine the route [1]. These drawbacks leads to the need of clustering concept. In clustering, nodes are organised into clusters that communicate with the local CH to transmit data to the sink, where end user can acquire it. In this way, communication distance between nodes and BS is reduced to transmit data. Thus, clustering is energy efficient communication protocol. But it also has its pros and cons. The local BS is always high energy node, if the BS is an energy constrained node, it would be die rapidly. Thus conventional clustering performance is not suitable for micro sensor networks as cluster heads (CHs) are fixed, this can also be referred to as static clustering. Dynamic clustering protocols were proposed to deal with static clustering issues [1, 2]

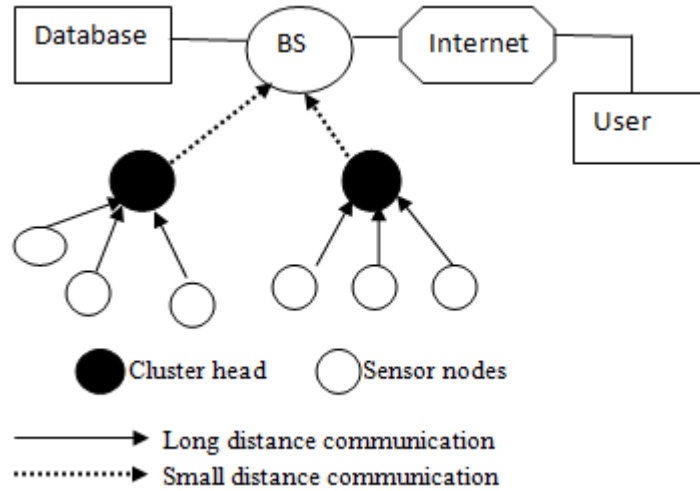

Fig.1. Clustering technique

## II. CLUSTER BASED ROUTING PROTOCOLS

The number of routing protocols are proposed to enhance energy efficiency and increased lifetime.

### 1. LEACH

The main clustering protocol exists for increasing energy efficiency is Low energy adaptive clustering hierarchy protocol (LEACH) [2]. It is self configuring, randomisation based protocol to distribute the energy load among nodes evenly. In this protocol every node has equal chance to become cluster head (CH). High energy node can take as CH. It does not expend the energy of single sensor because rotates among all sensors. It also perform the function of data fusion in order to reduce the data packet size which is being sent from the clusters to the BS, further reducing energy consumption and extending the network lifetime. Operation of LEACH is divided into rounds which is followed by set up and steady phase. In set up phase, clusters are organised while in steady phase, data transmission takes place. Steady phase has longer session than set up phase. Instead of these two phases, one more phase is Advertisement phase. During advertisement phase, nodes decides itself whether to be cluster head or not for current round. This decision is based upon node n by selecting random number between 0 and 1. If the chosen number is less than threshold T (n), then the node becomes a CH for the round. The threshold is calculated as-

$$T(n) = \begin{cases} \frac{p}{1-p * [r \bmod (\frac{1}{p})]} & \text{if } n \in G \\ 0 & \text{Otherwise} \end{cases}$$

Where P is the desired percentage of CH candidates, r is the current round and G is the set of nodes that have not been CH so far for the last 1/p rounds.

### 2. SEP

In 2004, Stable Election Protocol (SEP) was introduced for clustered heterogeneous wireless sensor networks [3]. It is proposed to prolong the stability period (time interval before the first node dies (FND)) essential for some applications whose feedback from the sensor network must be required. This protocol helps to improve the stability period of clustering hierarchy process. In order to achieve the increased stability period, SEP tries to balance energy consumption. In this, out of whole population some sensor nodes are provided with more energy than that of rest nodes (normal nodes) on the same network. Most probably advanced nodes become CH which is good fairness constraint. It ensures stability by using heterogeneity factors like fraction of advanced nodes and additional energy factor among advanced and normal nodes. This protocol has improvement over the existing LEACH as it increase the Epoch (optimal probability) of the wireless sensor network in proportion to energy augmentation. Initial energy is

not considered for heterogeneity of nodes in case of LEACH. Consequently, energy consumption of resources in sensor network is not optimized in the presence of such heterogeneity. SEP protocol ensures that the CH election process suitably adapted to deal with heterogeneity of nodes. LEACH is not efficient in heterogeneity of nodes, therefore, SEP is used to increase stability region in case of heterogeneous networks.

### 3. LEACH-EP

It is extension of LEACH protocol. Traditional protocol does not consider energy parameter to select the cluster head, but LEACH-EP [4] takes energy into account. In this protocol, higher residual energy node has more opportunities to become cluster head (CH). Energy based threshold is calculated as  $T_{ep}(n)$

$$p * \frac{E(n)}{E_{ch} - av(r-1)} \text{ if } E(n) \geq 0.5 * E_{ch\_av}(r-1)$$

$$0 \quad \text{if } E(n) < 0.5 * E_{ch\_av}(r-1)$$

Where  $E(n)$  is current residual energy of node  $n$ .

$E_{ch\_av}(r-1)$  is average residual energy of all CHs in previous round.

### 4. LEACH-DT

In [5], the authors proposed a distance based algorithm which is known as LEACH-DT to balance energy consumption among all nodes. This protocol self elects the CH based on probabilities that their distance to the sink. LEACH makes use of the same formula as original LEACH.

### 5. DEEC

LEACH, PEGASIS, HEED [2, 6, 7] all are assumed to be best and suitable for homogeneous sensor networks. The performance of these protocols will be poor in heterogeneous environments. It may be possible that nodes having energy will die out more quickly as compared to the nodes having high energy. Distributed Energy Efficient Clustering protocol (DEEC) [8] is developed for heterogeneous sensor networks. It not only prolongs the network lifetime but also stability period. SEP is proposed for two level hierarchical heterogeneous networks, which consists of two nodes of different types according to the initial energy. The advanced nodes are high energy nodes than normal nodes. SEP only increases the stability period. It is not fit for multilevel heterogeneous (WSNs), which includes nodes of more than two types. On the other hand, DEEC is well suited for two level heterogeneous networks as well as fit for multilevel hierarchical networks. Like LEACH, DEEC also does rotation of Cluster Head among all the nodes. CH selection process is based on the probability of ratio between the remaining energy of each node and the total energy of the network. Thus, round number of the rotation for each node is varied according to its initial and remaining energy.

### 6. NEAP

As we know that clustering schemes are not effective for the heterogeneous WSNs. A novel energy adaptive protocol (NEAP) is introduced to reduce overall power consumption and to prolong the lifetime of the network in a Heterogeneous WSNs. In NEAP [9] protocol, CH is selected based on threshold probability and it also considers certain parameters in order to form clusters such as nodes current battery power and number of current CH members, distance between CHs and nodes. It overcomes from LEACH limitations by considering sensor node concepts and some sensor node assumptions

### 7. ERP

It is new evolutionary based routing protocol [10] for clustered heterogeneous WSNs. Bio inspired algorithms are the algorithms which extend the network lifetime but at the cost of reduction in stability period. This presents trade off between lifetime and stability period. This is due to the one common parameter i.e. transmission distance which is not considered while designing fitness function. The motive of ERP protocol is to reduce the unwanted behaviour of Evolutionary Algorithm. It deals with clustered routing problem by designing new fitness function which considers parameters like cohesion (intra-distance) and separation error (inter-distance). This protocol helps in increasing stability period as well as stability period in heterogeneous wireless sensor networks. This protocol

basically refines the fitness function by redefining the distance function in order to serve two clustering purpose such as intra-distance and inter-distance.

### 8. SAERP

A new stable aware evolutionary routing protocol(SAERP) is proposed for both homogeneous and heterogeneous wireless sensor networks in order to ensure maximum stability and minimum instability periods [11]. It uses evolutionary modelling where cluster heads are selected in a more energy efficient way for well maintain balanced energy consumption. It uses energy based heuristics for initializing the individual solutions, evaluating the fitness and mutation to maintain longer stable and shorter instable regions. To deal with routing problems, no attempt has been made to investigate meta-heuristics techniques such as evolutionary algorithms(EA's). Still EA's has been used in handling various WSNs challenges but the development of EA based stable aware routing is not explored yet. In SAERP, the robust performance is obtained by introducing energy aware heuristics for population initialization and mutation operator while designing a suitable fitness function.

### 9. MBC protocol

As discussed earlier, most of the protocols are developed for stationary environment, but there are certain protocols designed for mobile sensor nodes. One of the most famous protocols is Mobility Based Clustering (MBC) protocol [12] for mobile wireless sensor networks. In the proposed protocol, the sensor nodes elects itself as cluster head based on parameters such as its residual energy and mobility. A non CH node establishes a stable data link with CH node during clustering within the pre-specified connection time. CH nodes provides the TDMA schedule to each non CH node for data transmission in ascending order within pre-assigned connection time. During steady state phase, the leaf sensor nodes sends sensed information to the CH according to its allocated time schedule and then sends join request message to new cluster in case of failure of the connection with previous CH. In this way, the protocol reduces the overhead and packet loss rate.

## III. OPTIMIZATION STRATEGIES.

Over the last decades, many researchers have concentrated their research work on WSNs. Various issues like energy minimization, quality of service, security management etc have been widely explored. There are critical issues such as energy efficiency, quality of service, and security. Optimization is basic necessity to obtain better results in one of any these issues. Moreover in number of applications such as health monitoring networks, vehicular ad-hoc networks (VANET's) these issue might contradict and require tradeoff between them. The use of traditional algorithms were not suitable regarding it due to the high energy harvesting and data processing requirements. Regarding this, the researchers started using bio mimic optimization strategies in WSNs. These techniques are adverse and includes many various optimization algorithms. The most commonly used bio-mimic algorithms are particle swarm optimization, genetic algorithms, ant colony optimization. Optimization refers to applied science in which parameters values are obtained that facilitates an objective function so that some minimum as well as maximum values can be produced [13].

### Particle swarm optimization in WSNs

PSO comprises of a swarm of candidate solutions known as particles. Many revised versions of PSO have come into existence by introducing new parameters and factors [14].The three steps that define the PSO technique are generation of particles velocity and position, update of velocity and position update. Nodes can be positioned static or mobile. The researchers tried to minimize the hole coverage area by using PSO – Voronoi algorithm for static positioning of nodes. The fitness of WSN's coverage can be assessed by using Voronoi diagram. Depending upon the fitness, PSO looks for the most suitable location of the sensors. Instead of static node positioning, a hybrid approach is also used in mobile nodes. A modified PSO which is known as particle swarm genetic optimization (PSGO) is used to serve this purpose.

### Ant colony Optimization

Social behaviour of ants also inspired a number of technique and methods like other swarm intelligence methods that also inspired from animals and insects behaviour.ACO is based upon foraging behaviour of some ants

species.ACO is helpful in many engineering domains for solving discrete optimization problems. The basic foraging behaviour of ants is presented as [16].

- a. In first step, food source will find out by the ants, and then return back to the nest and leave behind a pheromone trail.
- b. Ants will follow all possible routes.
- c. Ants will take the shortest route.

#### Genetic algorithm (GA)

GA is evolutionary type of algorithm based on the abstraction of biological systems.GA can be characterized as a global search heuristic. It makes use of selection, crossover and mutation operators for getting suitable global answer. Another one elitism operator is used to store the best chromosomes for the next generation. Here population is termed as chromosomes and the candidate solutions are termed as individuals.GA has two mainly merits over conventional algorithms .The first one is capability of handling complex problems. Another one is that it can deal with all types of objective functions such as linear or nonlinear, continuous or discontinuous, stationary or transient

#### IV. COMPARISON BETWEEN PROPOSED PROTOCOL

*Table1. Difference between routing protocols*

PROTOCOL	PREDICTION RELATED	DATA TRANSMISSION	EVOLUTIONARY RELATED	ENERGY EFFICIENCY
<b>LEACH</b>	No	Single hop	No	Poor
<b>SEP</b>	No	Single hop	No	Good
<b>DEEC</b>	Yes	Single hop	No	Good
<b>HEED</b>	No	Single hop	No	Good
<b>NEAP</b>	No	Multi-hop	No	Good
<b>ERP</b>	No	Single hop	Yes	Good
<b>SAERP</b>	No	Singe hop	Yes	Good

#### COMPARISON BETWEEN PSO, ACO AND GA

*Table2. Functional comparison between optimization strategies*

ALGORITHM NAME	MERITS	DEMERITS
<b>PSO</b>	<ul style="list-style-type: none"> <li>• Implementation is easy</li> <li>• Only few parameters are required to be adjusted</li> <li>• Effective global searching</li> </ul>	<ul style="list-style-type: none"> <li>• Can't used for high speed real time applications</li> <li>• It fails in case of frequently optimization</li> </ul>
<b>ACO</b>	<ul style="list-style-type: none"> <li>• Can be dynamically adapted in some applications</li> <li>• Fast discovery of best solutions results from positive feedback</li> </ul>	<ul style="list-style-type: none"> <li>• Tough theoretical analysis</li> <li>• Straightforwardcoding doesn't exist</li> </ul>
<b>GA</b>	<ul style="list-style-type: none"> <li>• Not dependent</li> <li>• Each optimization problem having chromosome can be solved with encoding</li> <li>• Easily transferrable to other existing models.</li> </ul>	<ul style="list-style-type: none"> <li>• Running times are more</li> <li>• Optimization response time is not constant</li> <li>• Stop criterion is not clear in every problem</li> </ul>



## V. CONCLUSION AND FUTURE WORK

Over the last few years, Wireless Sensor Networks have attracted greater attention in various fields of applications. Examples include battlefield surveillance, remote monitoring etc. In these applications, energy consumption is major issue. In order to deal with this severe issue, researchers explored many clustering routing protocols. LEACH is the representative one. Though, LEACH outperforms the static clustering and traditional protocols but it is not suitable for heterogeneous wireless sensor networks. This means that LEACH doesn't consider the impact of node heterogeneity, in terms of their energy. Various heterogeneous aware protocols such as SEP, NEAP are introduced to deal with such heterogeneity of nodes. This paper also has presented review on evolutionary algorithms like ERP, SAERP which are developed to overcome the clustering problems. In this paper, we have presented the latest clustering protocols in WSNs and classified the schemes according to the single hop, multi-hop categories and homogeneous and heterogeneous networks. Most commonly issues for such protocols are how to select and form CHs so that less energy can be consumed due to the redundant messages sent to the BS. In enhanced mechanism for clustering schemes, the most important QOS requirements are needed such as network lifetime, fault tolerance. Many of the recent researches focuses on homogeneous type of wireless sensor networks while there are few researches on the heterogeneous which are more appropriate for real life applications. It was seen that most of the recent routing protocols presume that the sensor nodes and sink are stationary not mobile. However, there are some situations or applications which requires to be sensor nodes and sink mobile not stationary. In this survey, we have given complete overview of the three important methods namely PSO, ACO and GA. Hybrid approaches can also be adopted such as combination of genetic algorithm and simulated annealing for better results in optimization.

## REFERENCES

1. W. Heinzelman, A. Chandrakasan and H. Balakrishnan, "Energy-Efficient Communication Protocol for Wireless Microsensor Networks," *Proceedings of 33rd International Conference on System Sciences, Hawaii, 2000*, p. 10.
2. W. Heinzelman, A. Chandrakasan and H. Balakrishnan, 'An application-specific protocol architecture for wireless microsensor networks', *IEEE Transactions on Wireless Communications*, vol. 1, no. 4, pp. 660-670, 2002.
3. G. Smaragdakis, I. Matta, and A., "SEP: A stable election protocol for clustered heterogeneous wireless sensor networks," *Second International Workshop on Sensor and Actor Network Protocols and applications 2004*.
4. T. LU, Q. ZHU and Y. ZHU, 'Energy-balanced adaptive clustering algorithm for wireless sensor network', *Journal of Computer Applications*, vol. 32, no. 11, pp. 3107-3111, 2012.
5. S. Kang and T. Nguyen, 'Distance Based Thresholds for Cluster Head Selection in Wireless Sensor Networks', *IEEE Communications Letters*, vol. 16, no. 9, pp. 1396-1399, 2012.
6. S. Lindsey, C.S. Raghavenda, PEGASIS: "power efficient gathering in sensor information systems", in: *Proceeding of the IEEE Aerospace Conference, Big Sky, Montana, O. Younis, S. Fahmy March 2002*
7. O. Younis and S. Fahmy, 'HEED: a hybrid, energy-efficient, distributed clustering approach for ad hoc sensor networks', *IEEE Trans. on Mobile Comput.*, vol. 3, no. 4, pp. 366-379, 2004.
8. L. Qing, Q. Zhu and M. Wang, 'Design of a distributed energy-efficient clustering algorithm for heterogeneous wireless sensor networks', *Computer Communications*, vol. 29, no. 12, pp. 2230-2237, 2006.
9. Mehdi Golsorkhtabar, FarzadKavianiNia, Mehdi Hosseinzadeh, YonesVejdanparast, "The Novel Energy Adaptive protocol for Heterogeneous Wireless Sensor Networks", 2010, *IEEE*.
10. B. Attea and E. Khalil, 'A new evolutionary based routing protocol for clustered heterogeneous wireless sensor networks', *Applied Soft Computing*, vol. 12, no. 7, pp. 1950-1957, 2012.
11. E. Khalil and B. Attea, 'Stable-Aware Evolutionary Routing Protocol for Wireless Sensor Networks', *Wireless Pers Commun*, vol. 69, no. 4, pp. 1799-1817, 2012
12. S. Deng, L. Shen and J. Li, 'Mobility-based clustering protocol for wireless sensor networks with mobile nodes', *IET Wireless Sensor Systems*, vol. 1, no. 1, pp. 39-47, 2011.
13. M. Adnan, M. Razzaque, I. Ahmed and I. Isnin, 'Bio-Mimic Optimization Strategies in Wireless Sensor Networks: A Survey', *Sensors*, vol. 14, no. 1, pp. 299

**[Swati, 4(7): July 2017]**

**DOI- 10.5281/zenodo.823134**

**ISSN 2348 - 8034**

**Impact Factor- 4.022**

14. Y. del Valle, G. Venayagamoorthy, S. Mohagheghi, J. Hernandez and R. Harley, 'Particle Swarm Optimization: Basic Concepts, Variants and Applications in Power Systems', *IEEE Transactions on Evolutionary Computation*, vol. 12, no. 2, pp. 171-195, 2008.
15. M. Dorigo, V. Maniezzo and A. Coloni, 'Ant system: optimization by a colony of cooperating agents', *IEEE Transactions on Systems, Man and Cybernetics, Part B (Cybernetics)*, vol. 26, no. 1, pp. 29-41, 1996.